

SEC. # LARGE L.R. WINDOW SCALE 1/2" = 1'-0"

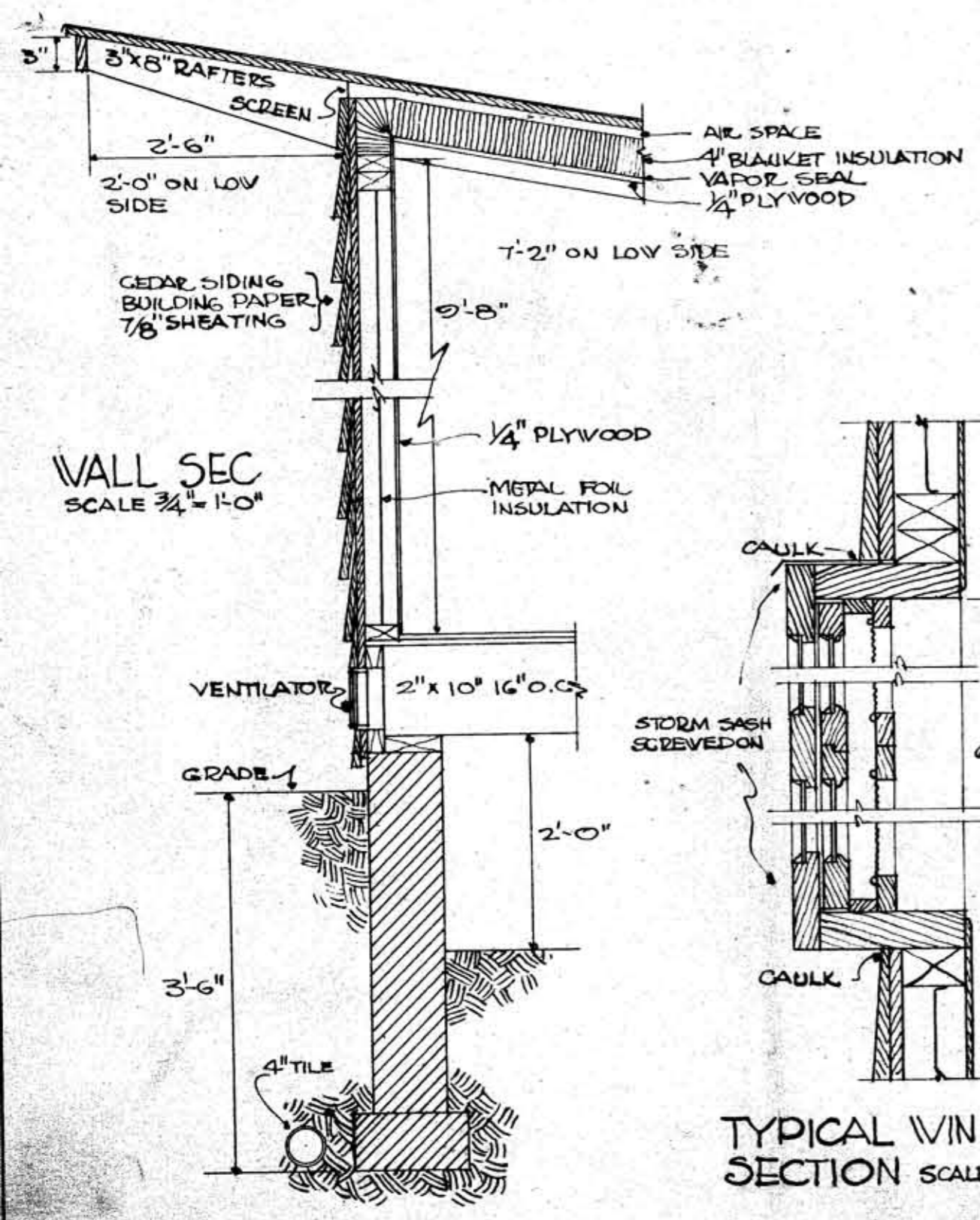

WALL SEC SCALE 3/4" = 1'-0"

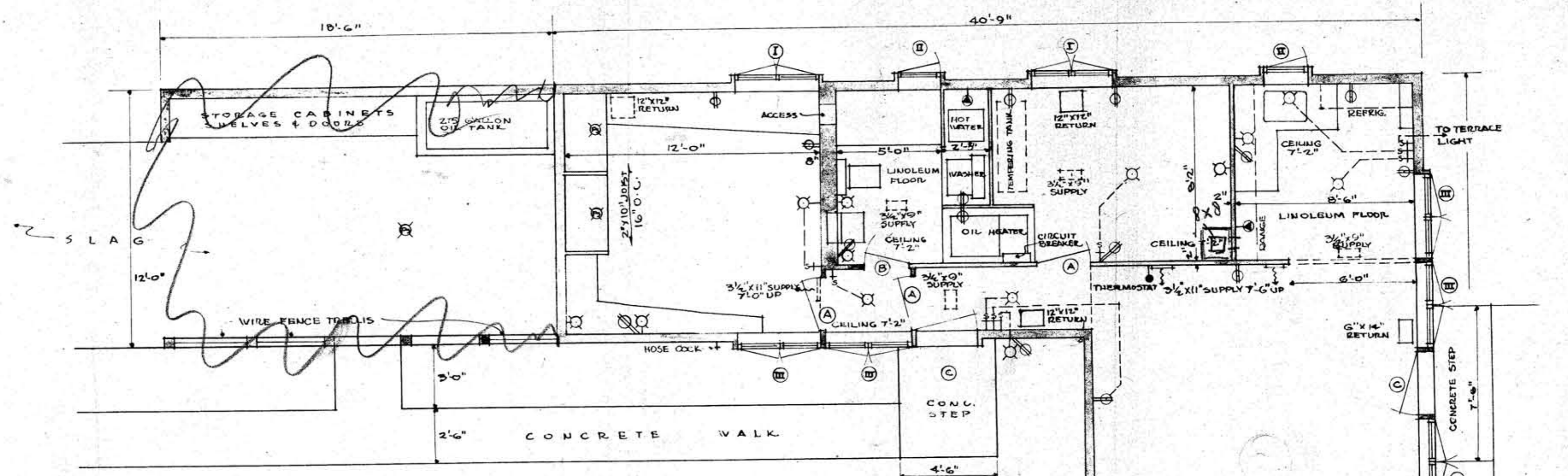
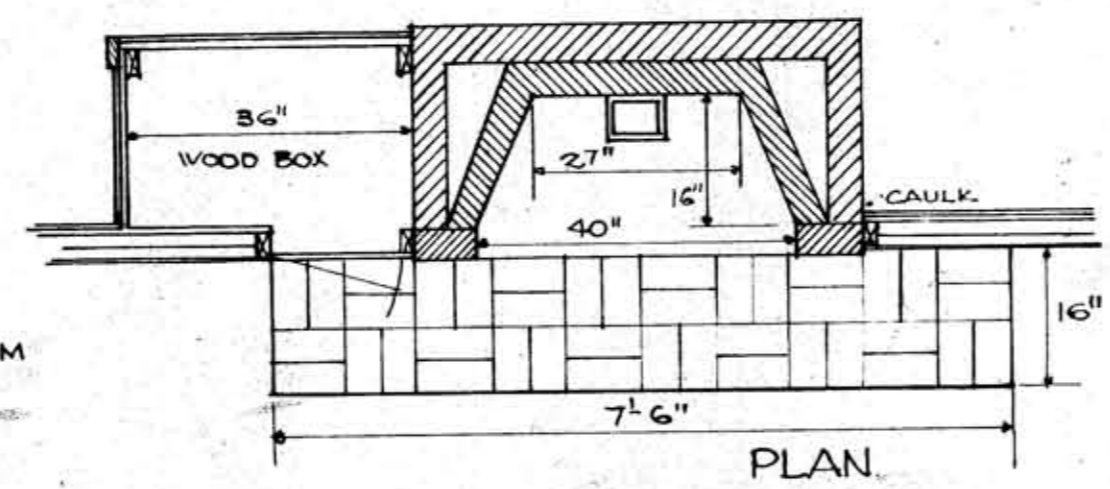
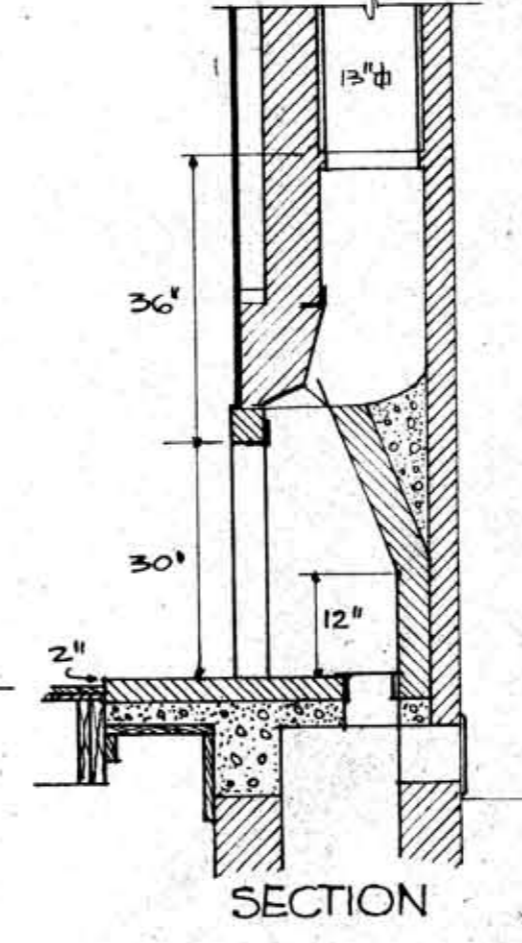
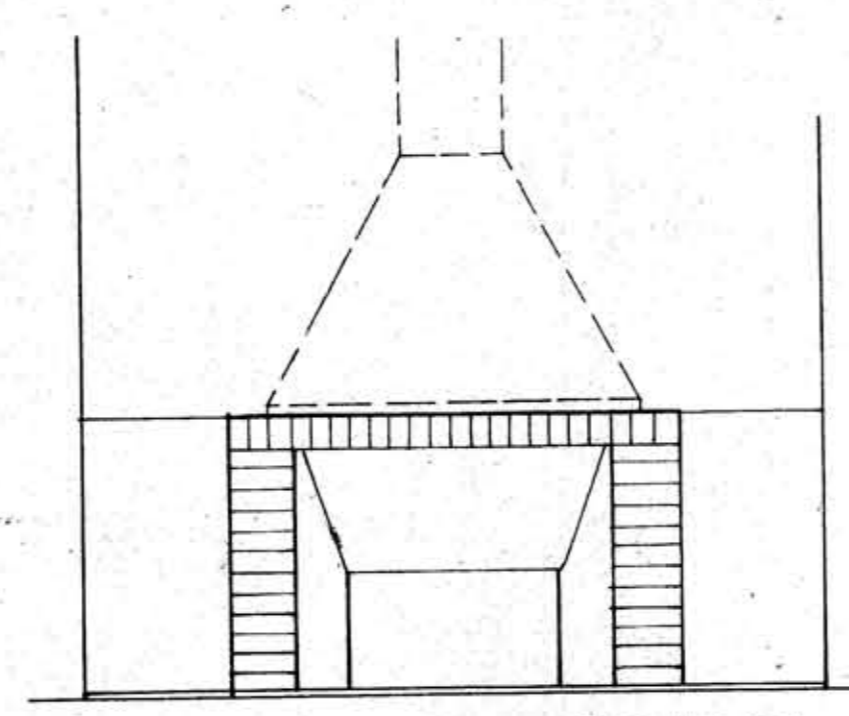

FIRE PLACE DETAILS SCALE 1/2" = 1'-0"

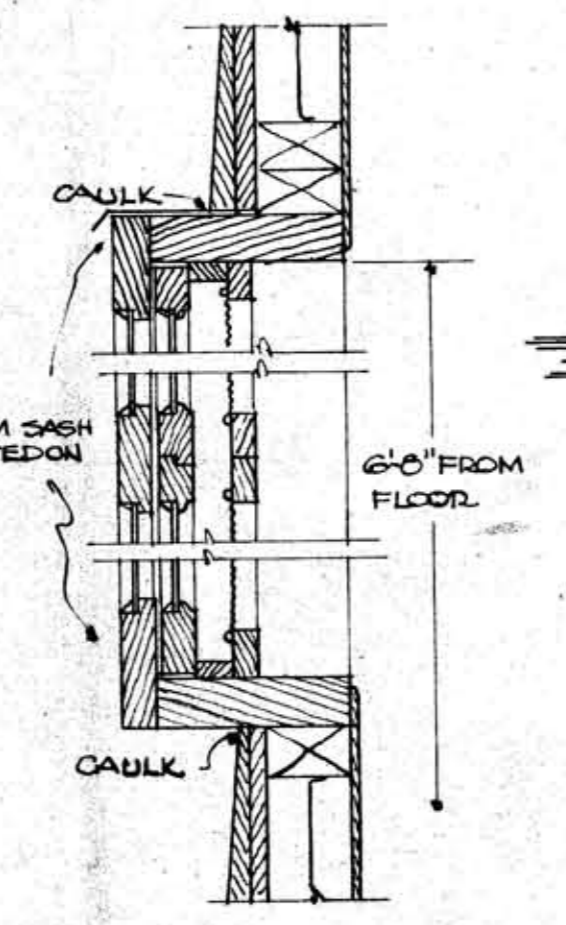

TYPICAL WINDOW SECTION SCALE 1/2" = 1'-0"

DOORS			WINDOWS					
MARK	THICK	SIZE	DESCRIPTION	MARK	LEAVES	OPENING SIZE	GLASS SIZE	DESCRIPTION
A	1 3/8"	26" X 6'-0"	FLUSH	I	2	4'-0" X 2'-10"	20" X 24"	CASEMENT
B	1 3/8"	20" X 6'-0"	"	II	1	2'-0" X 2'-10"	20" X 24"	"
C	1 3/4"	3'-0" X 6'-0"	"	III	2	4'-0" X 3'-0"	20" X 34"	"

BETTER HOMES & GARDENS  
★★★★★ HOME PLAN

NUMBER 1503

THIS PLAN CONFORMS TO THE STANDARDS OF THE FEDERAL HOUSING ADMINISTRATION FOR MINOR LOCAL VARIATIONS SEE YOUR F.H.A. REGIONAL OFFICE

DESIGNED BY W.D. RIDDLE A.I.A. CLEVELAND OHIO

SHEET NO. 1



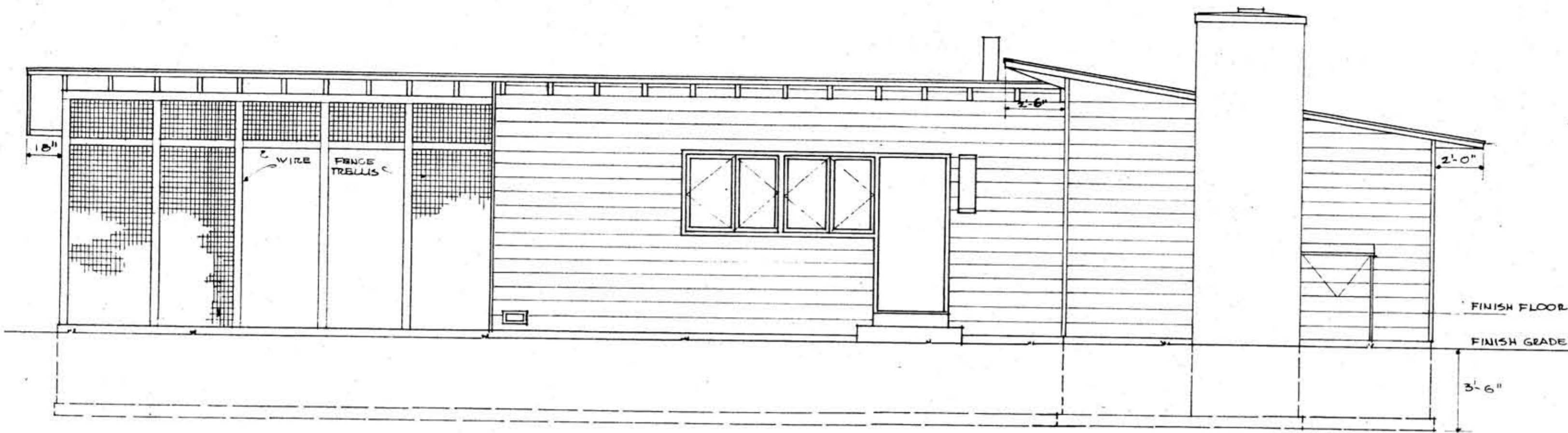

RIGHT SIDE

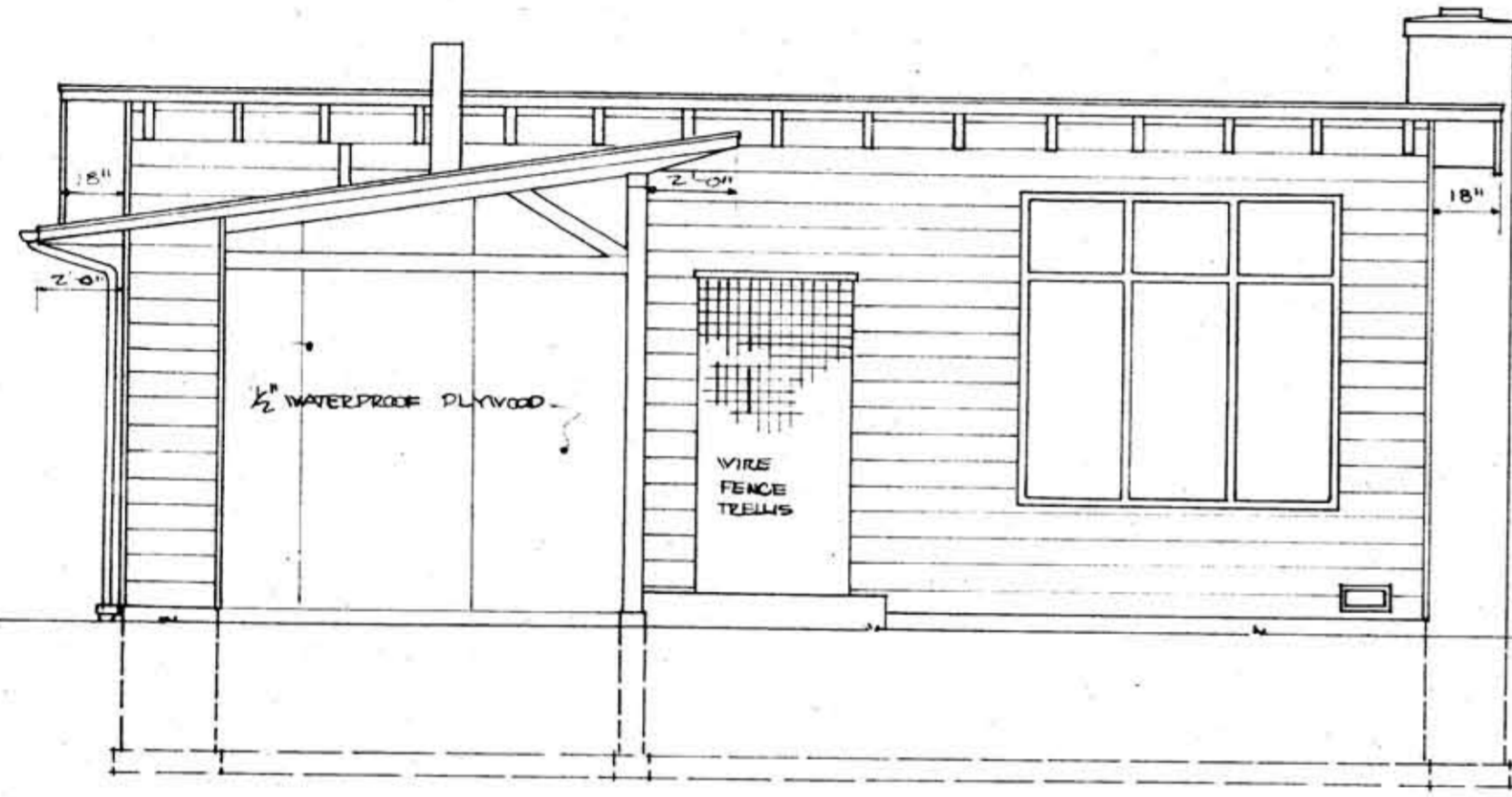

FRONT

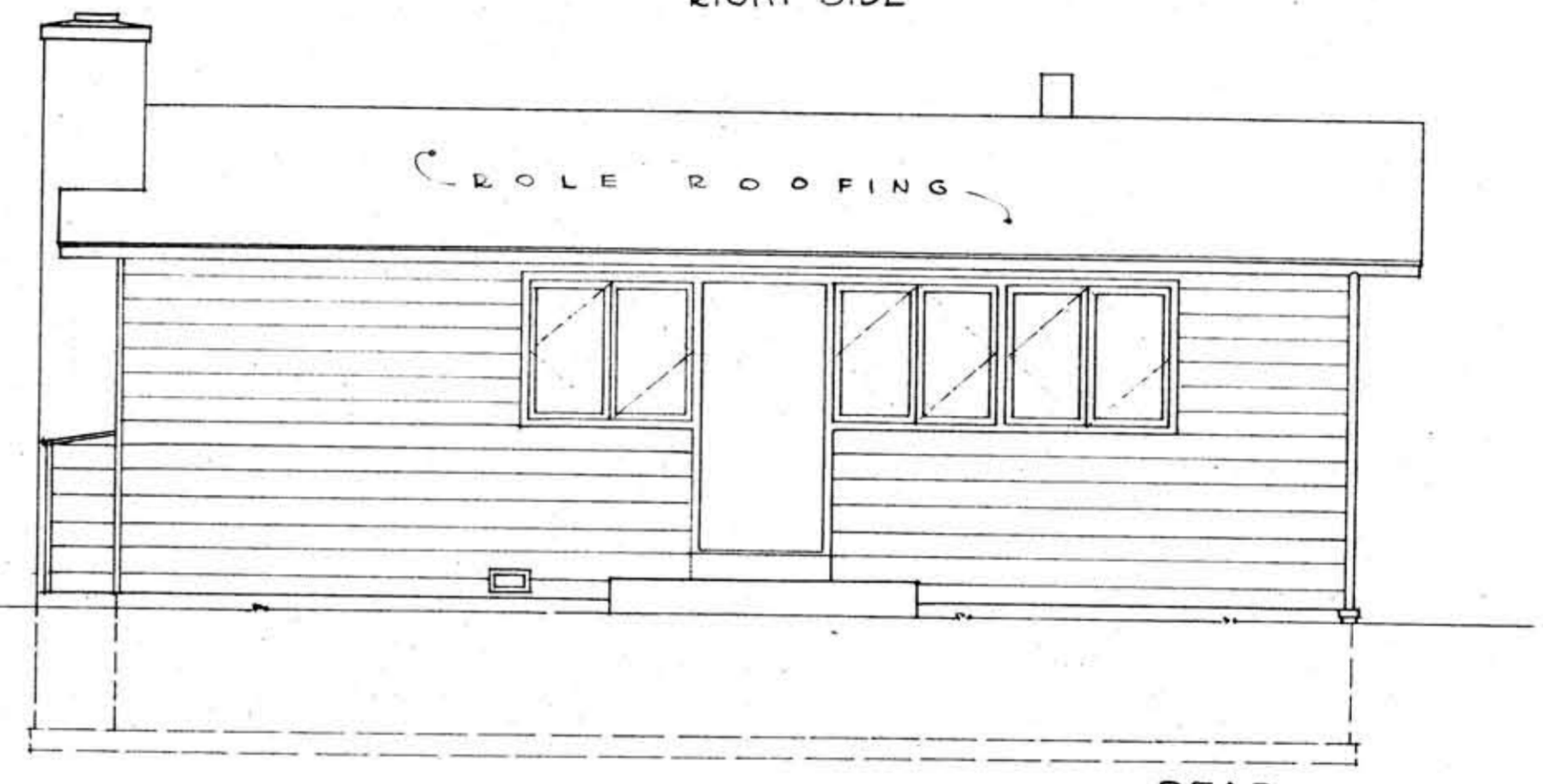

REAR

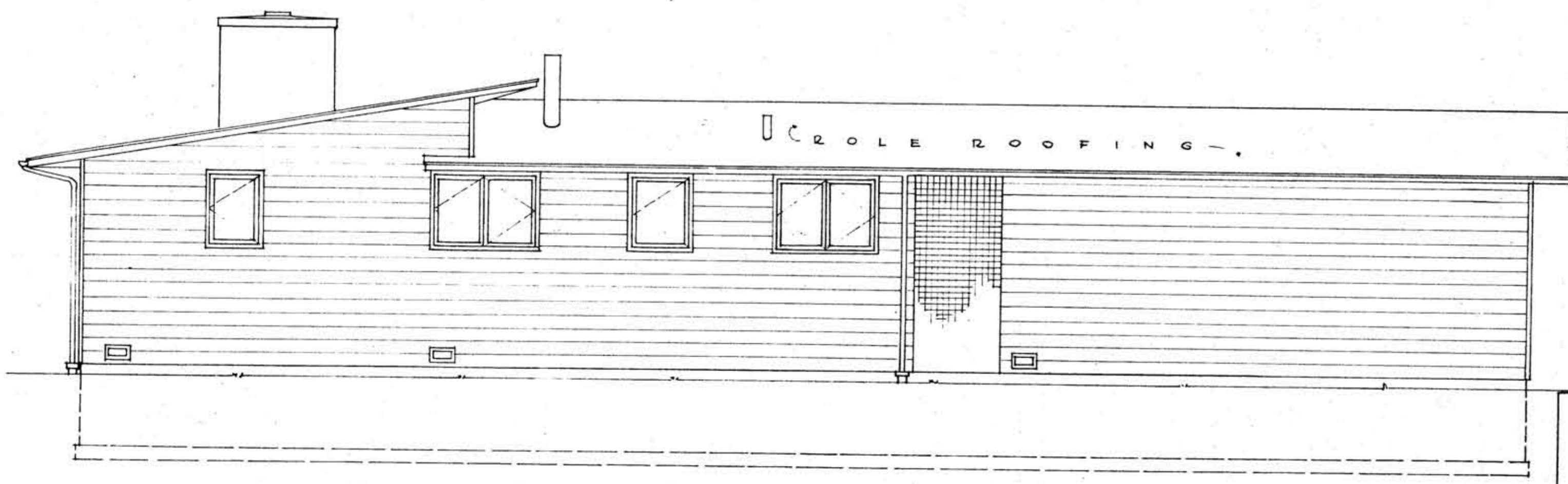

LEFT SIDE

**BETTER HOMES & GARDENS**  
**★★★★★HOME PLAN**

NUMBER <b>1503</b>	THIS PLAN CONFORMS TO THE STANDARDS OF THE <b>FEDERAL HOUSING ADMINISTRATION</b> FOR MINOR LOCAL VARIATIONS SEE YOUR F.H.A. REGIONAL OFFICE	SHEET NO. <b>2</b>
DESIGNED BY W.D. RIDDLE A.I.A. CLEVELAND OHIO		



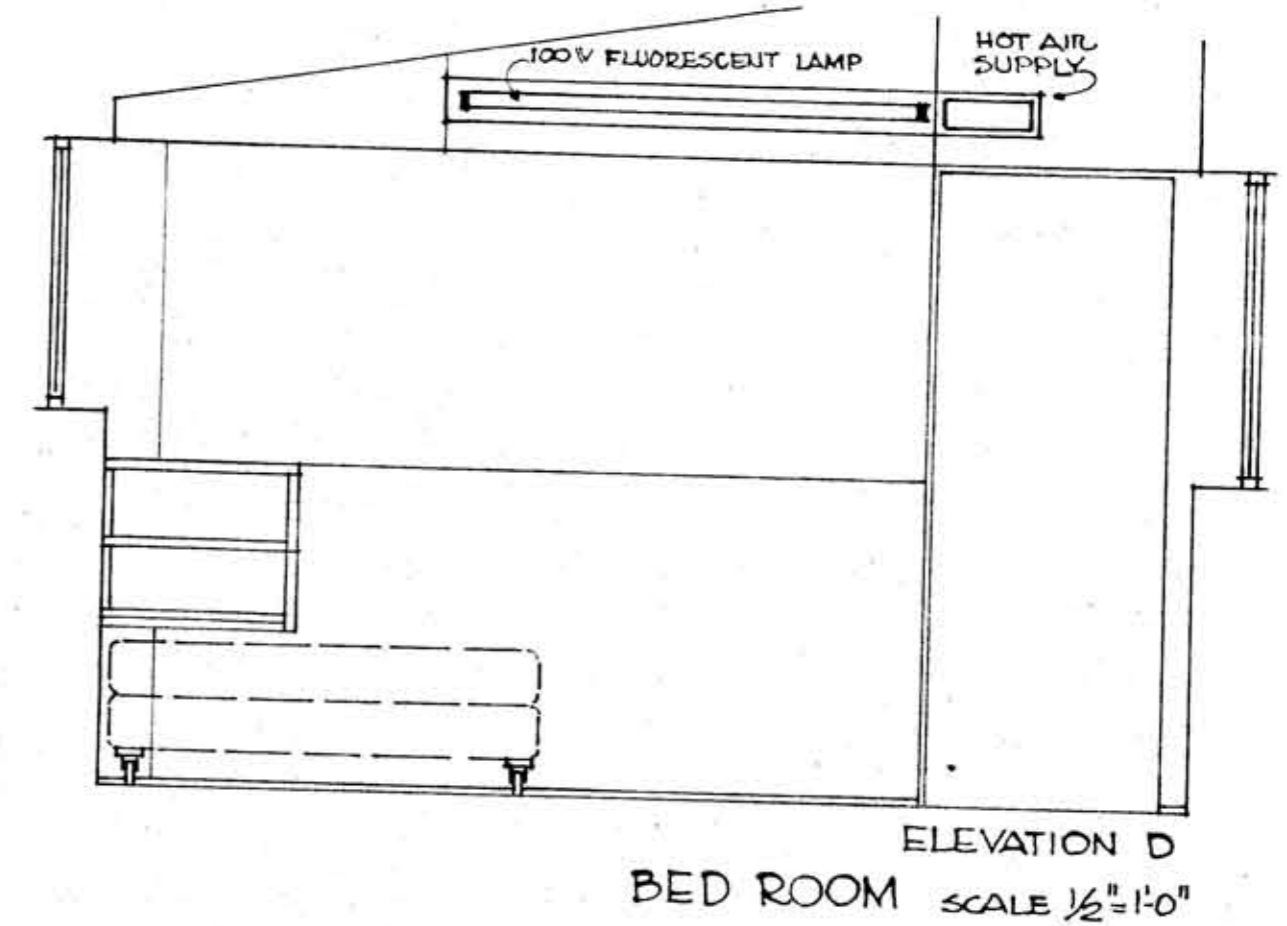
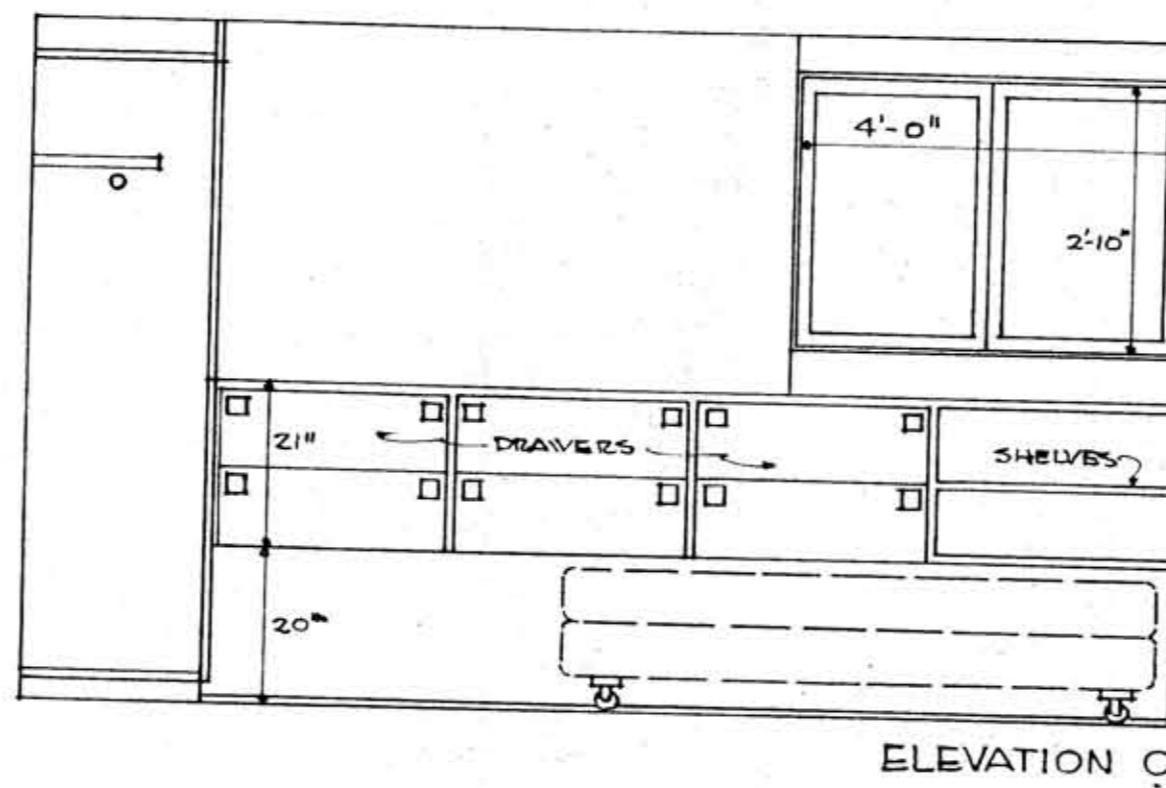
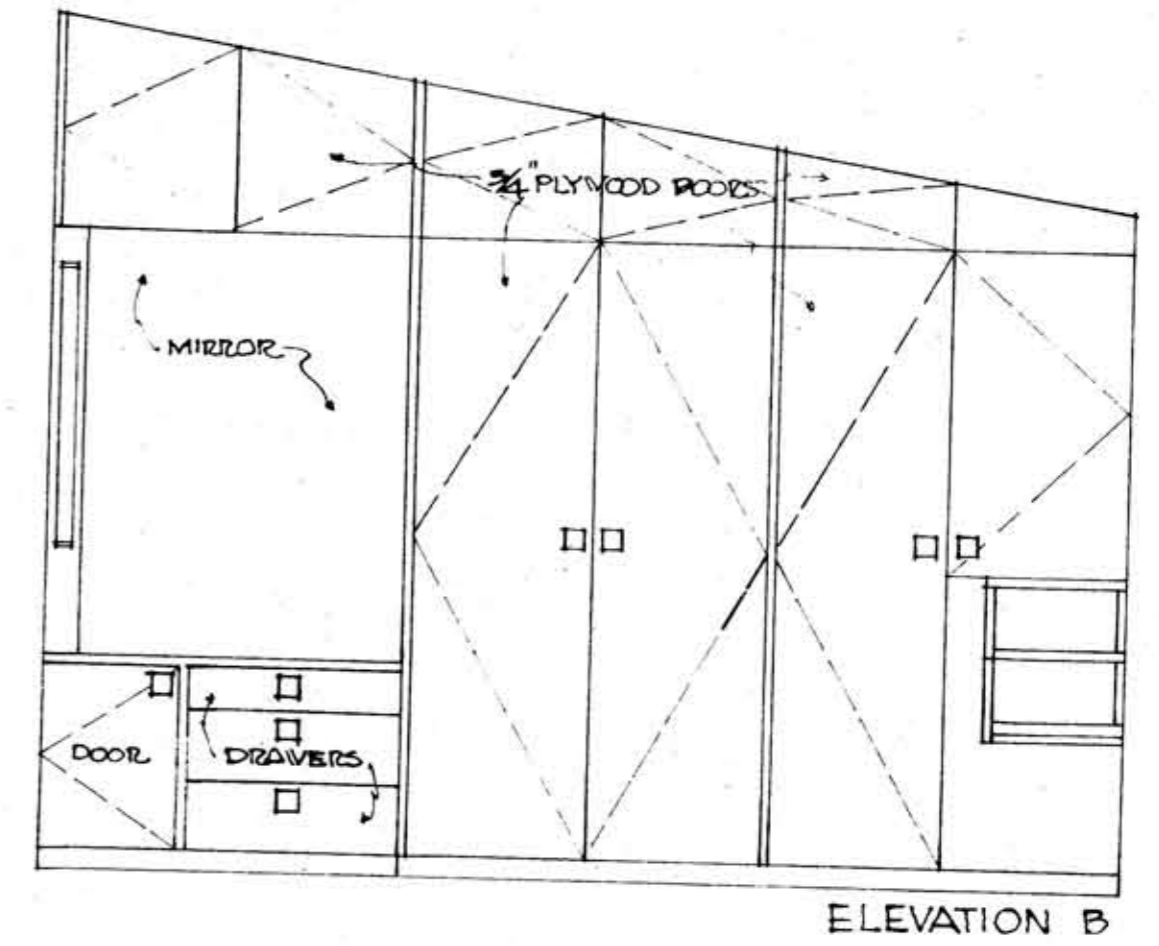
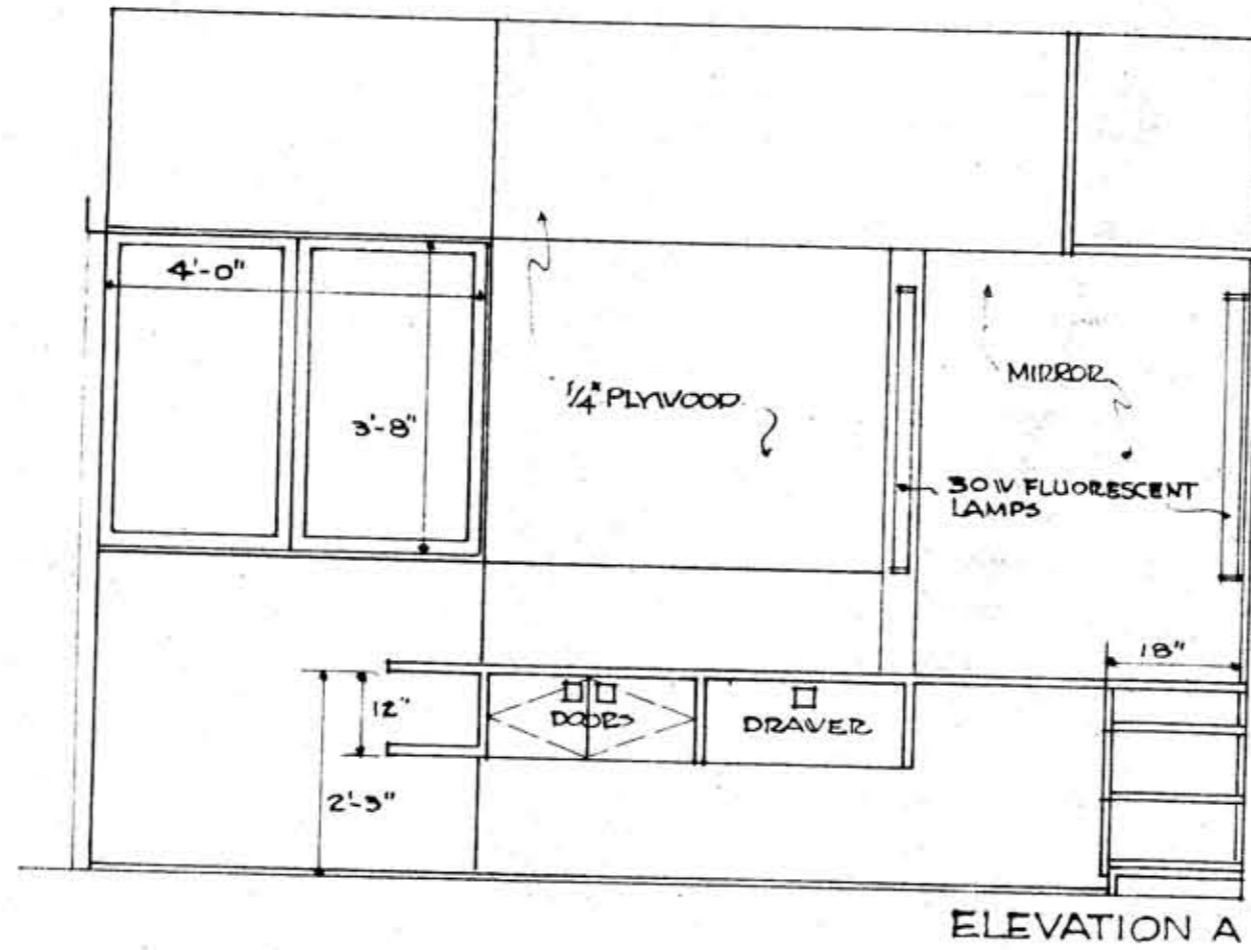
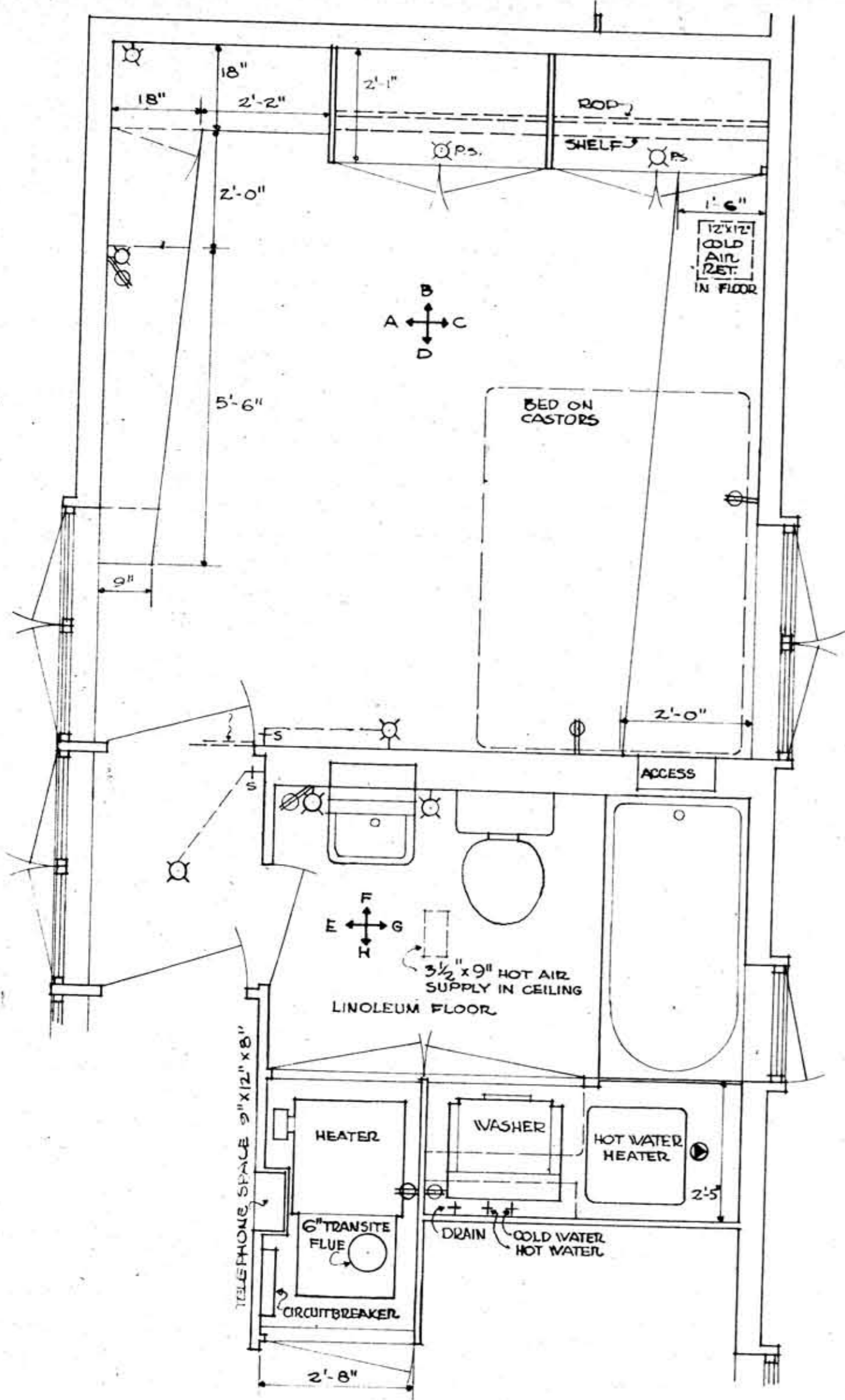

BED ROOM SCALE 1/2" = 1'-0"

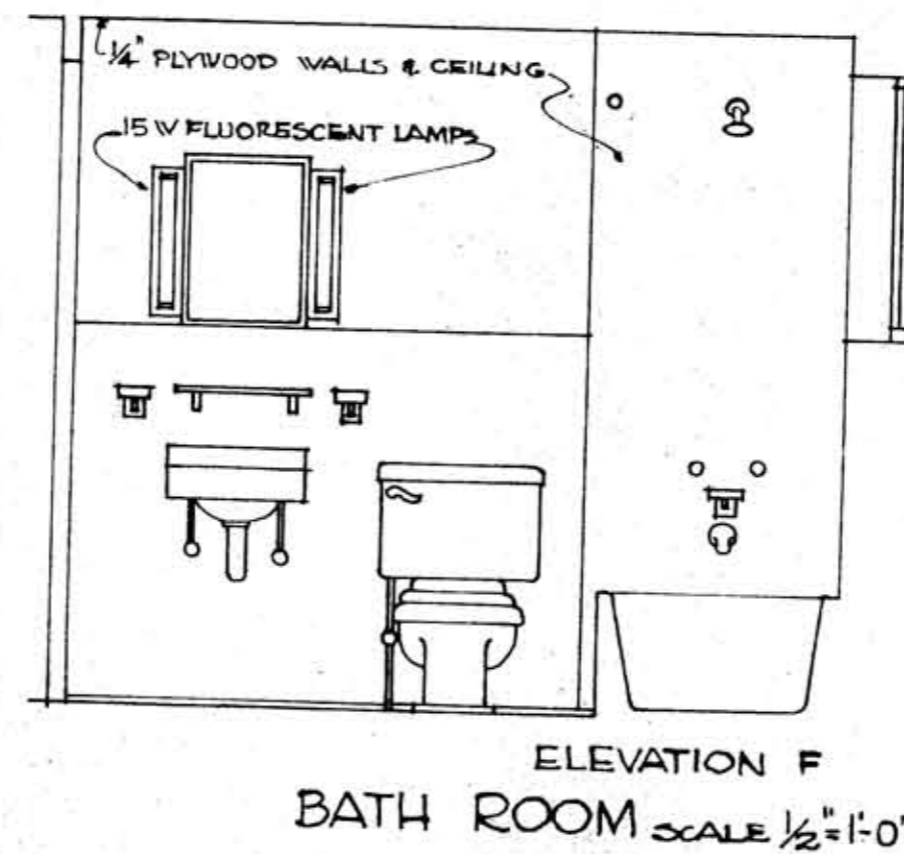
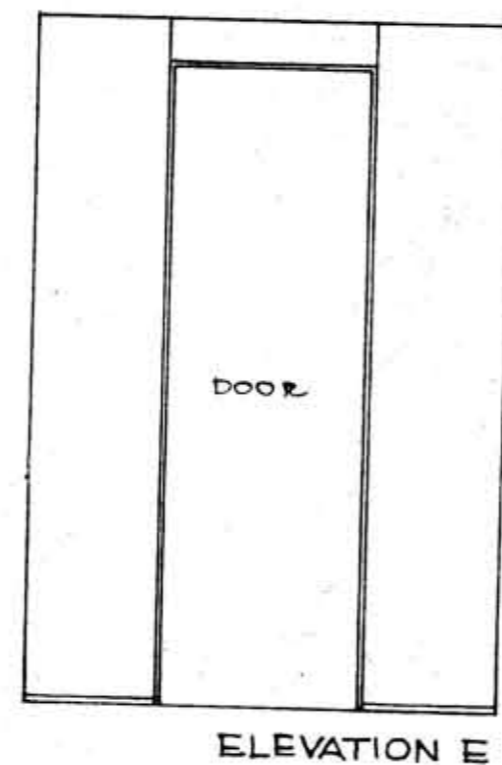
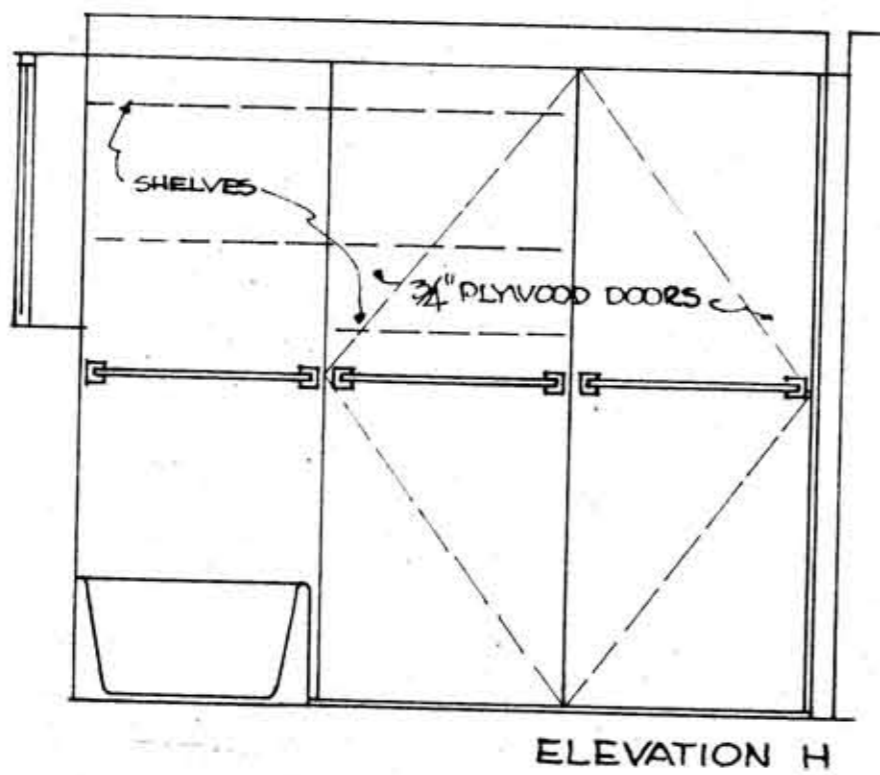
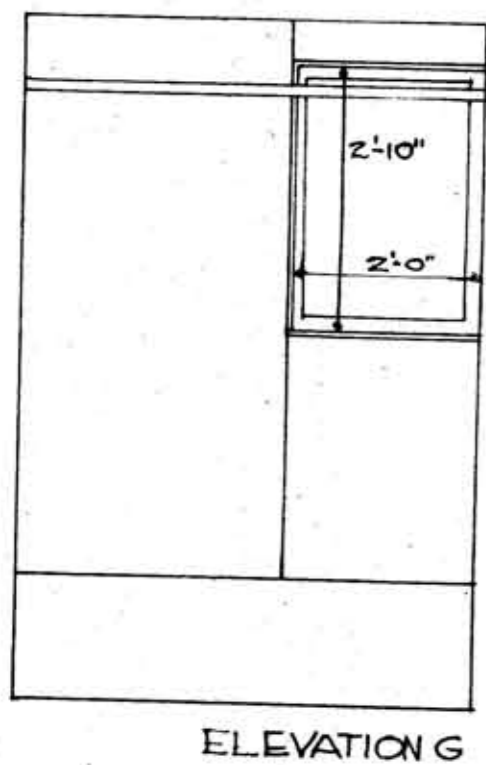

BATH ROOM SCALE 1/2" = 1'-0"

**BETTER HOMES & GARDENS**  
 ★★★★★ HOME PLAN

NUMBER 1503	THIS PLAN CONFORMS TO THE STANDARDS OF THE <b>FEDERAL HOUSING ADMINISTRATION</b> FOR MINOR LOCAL VARIATIONS SEE YOUR F.H.A. REGIONAL OFFICE	SHEET NO. <b>3</b>
DESIGNED BY W. D. RIDDLE A.T.A. CLEVELAND OHIO		

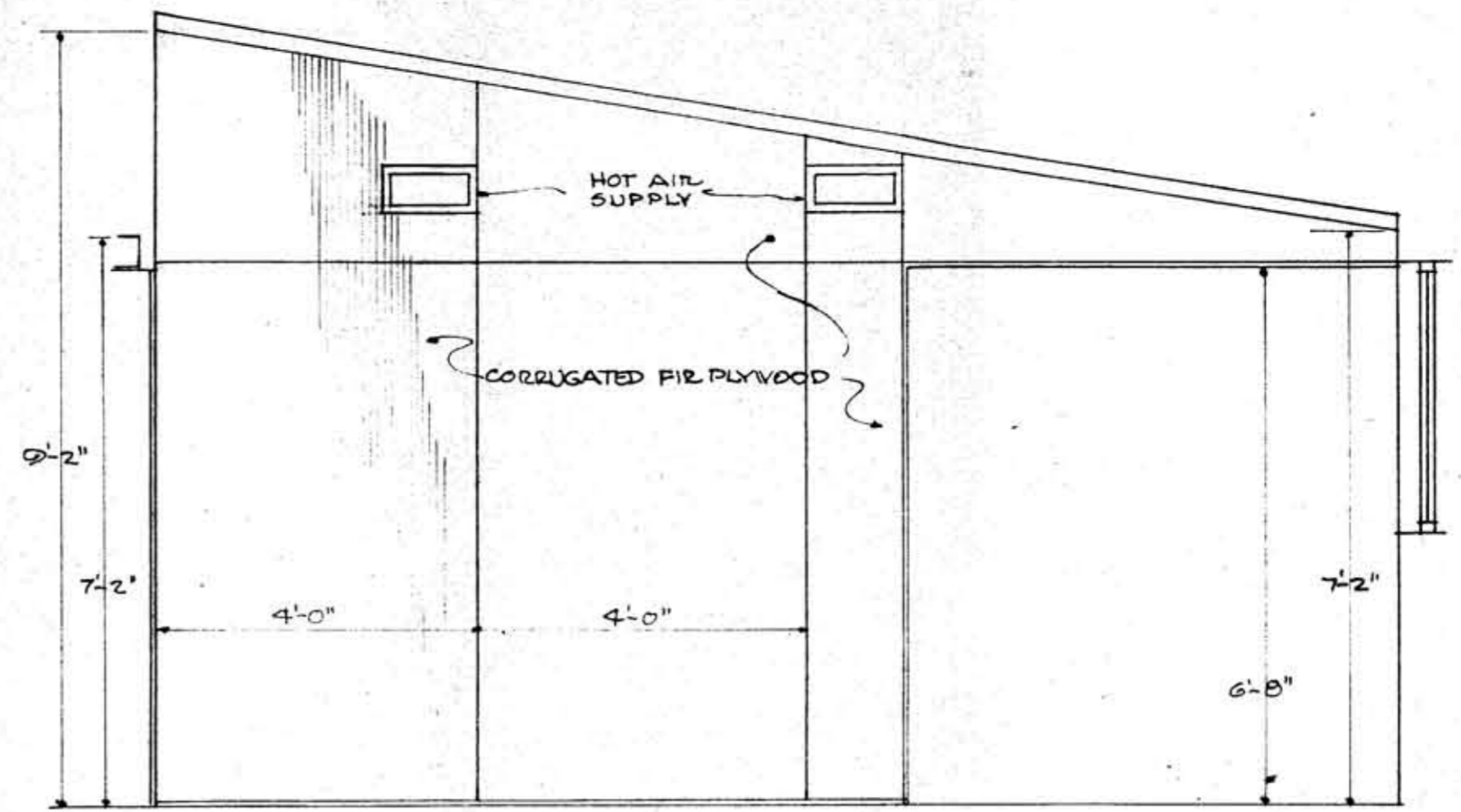
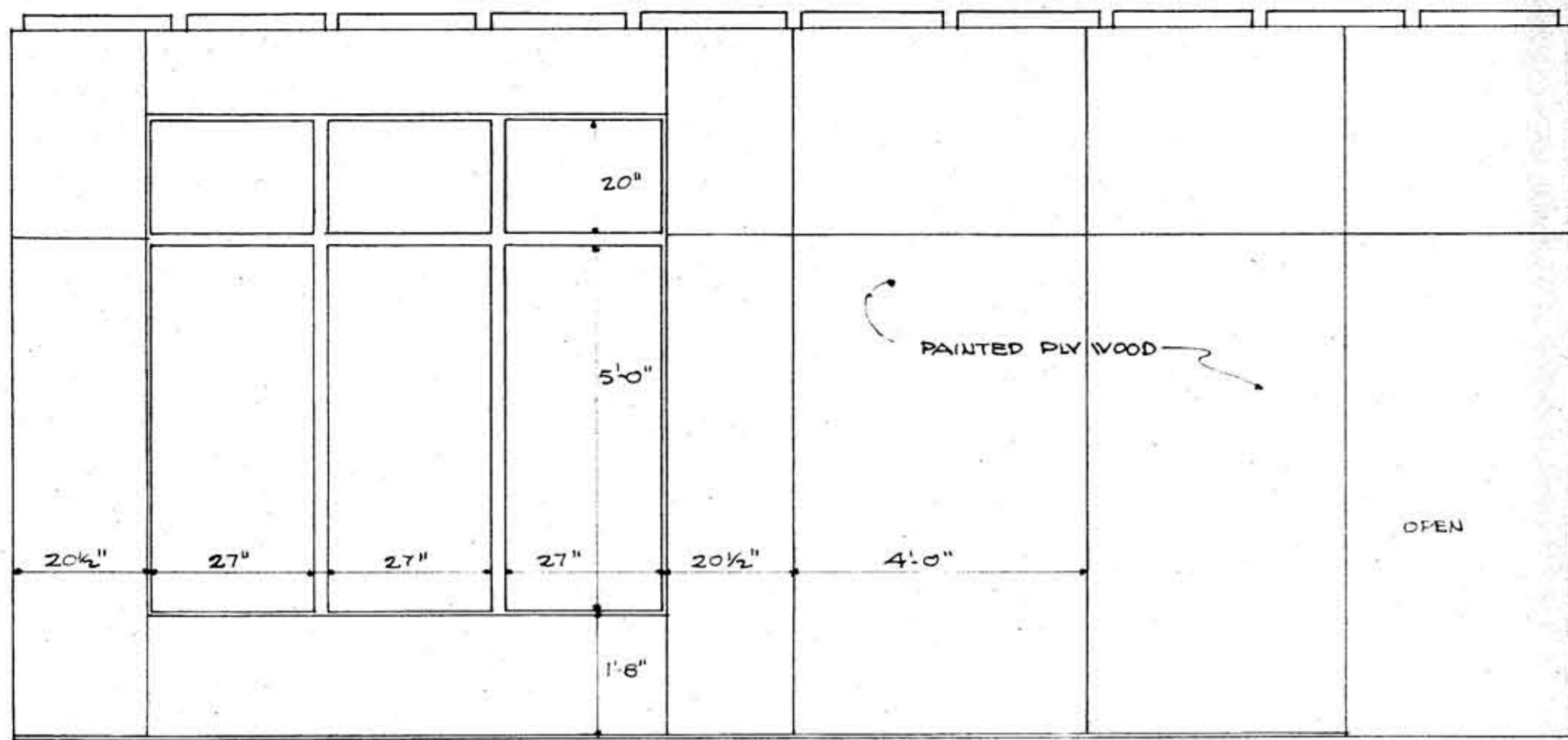

LIVING ROOM WALLS SCALE 1/2" = 1'-0"

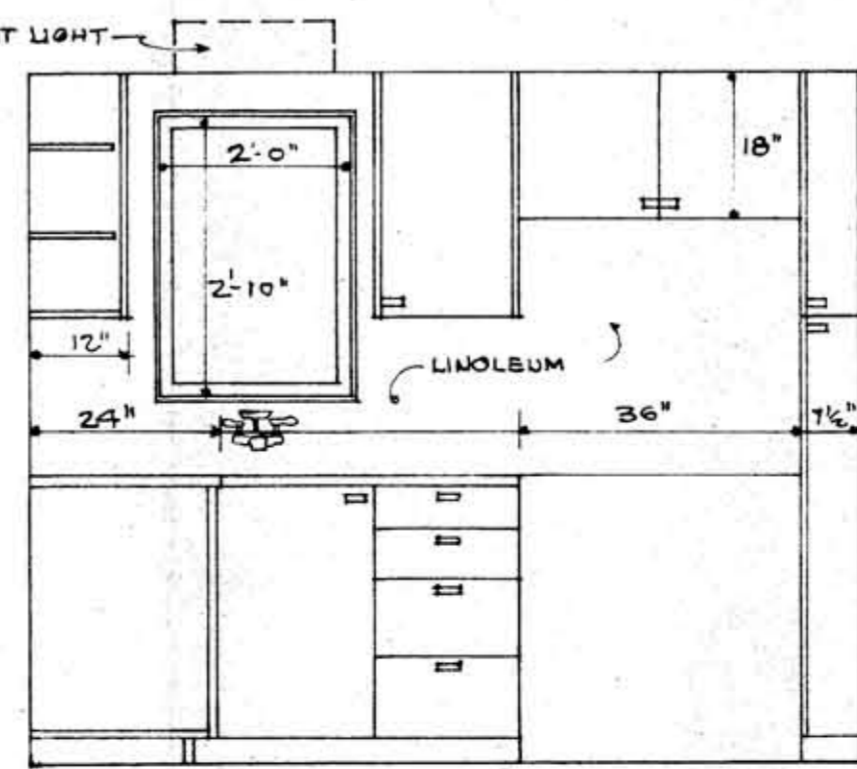
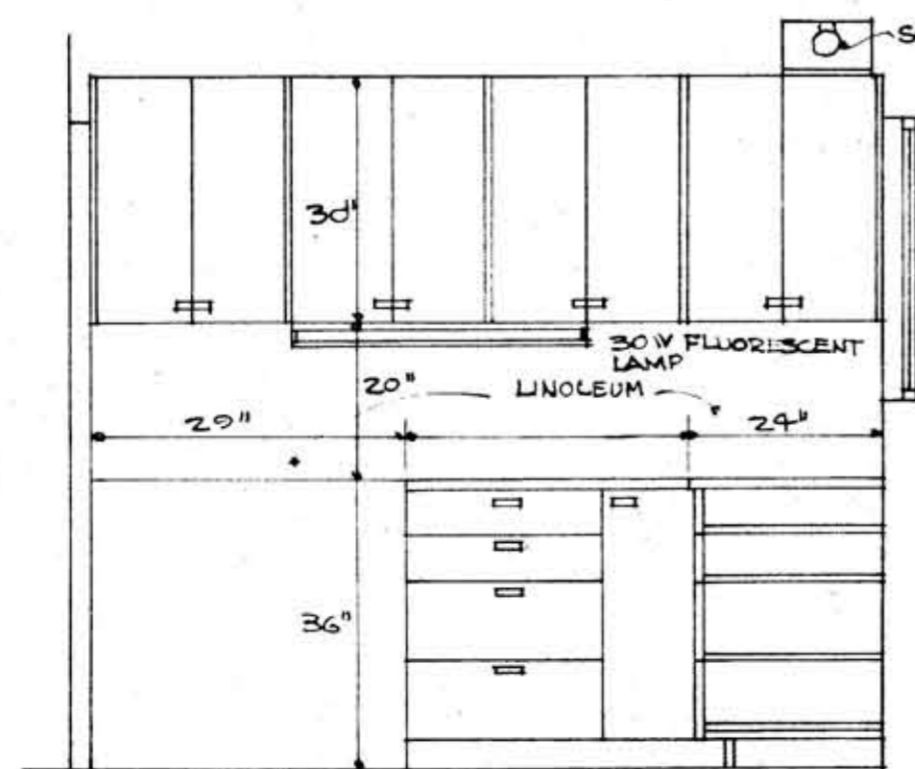
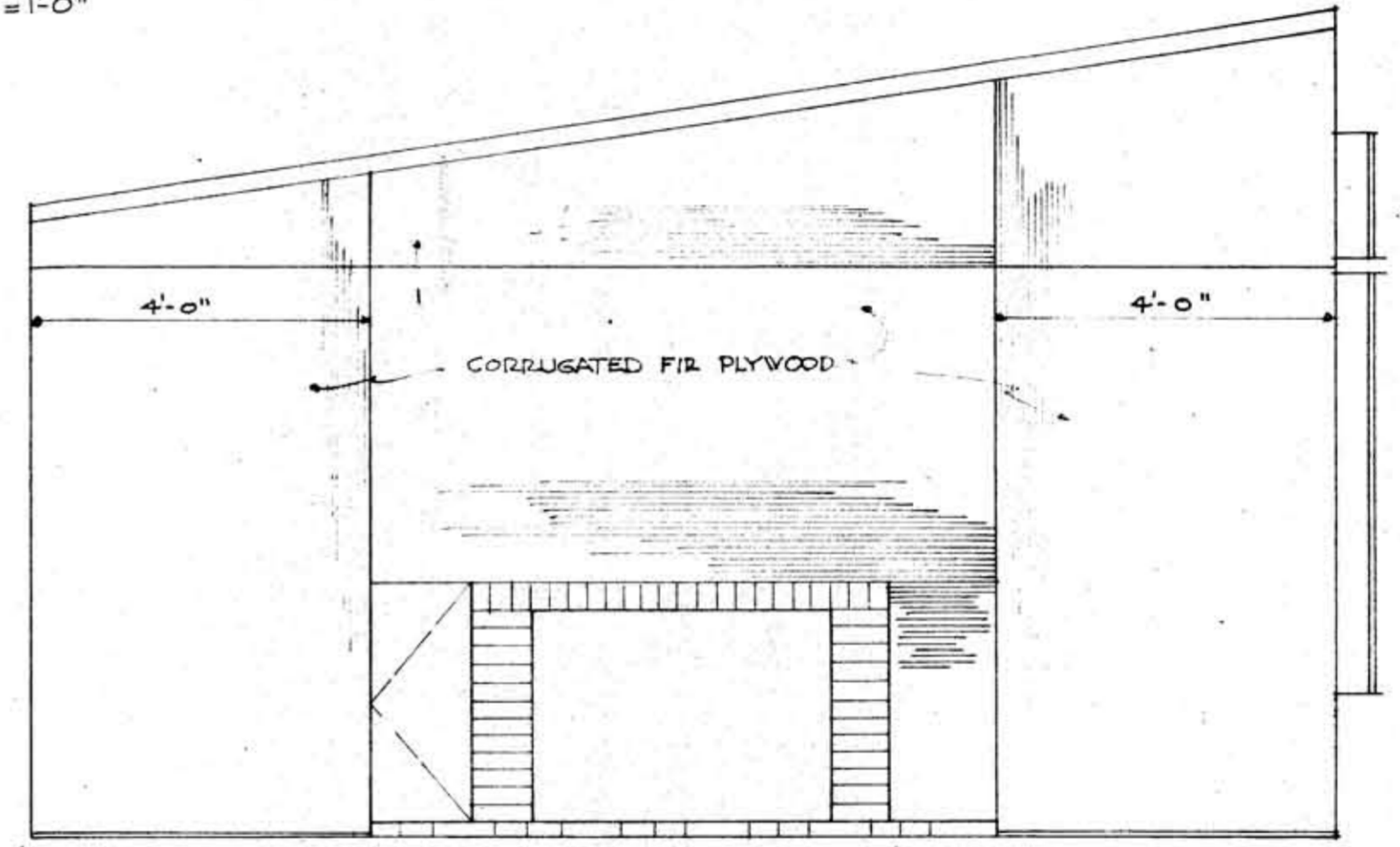
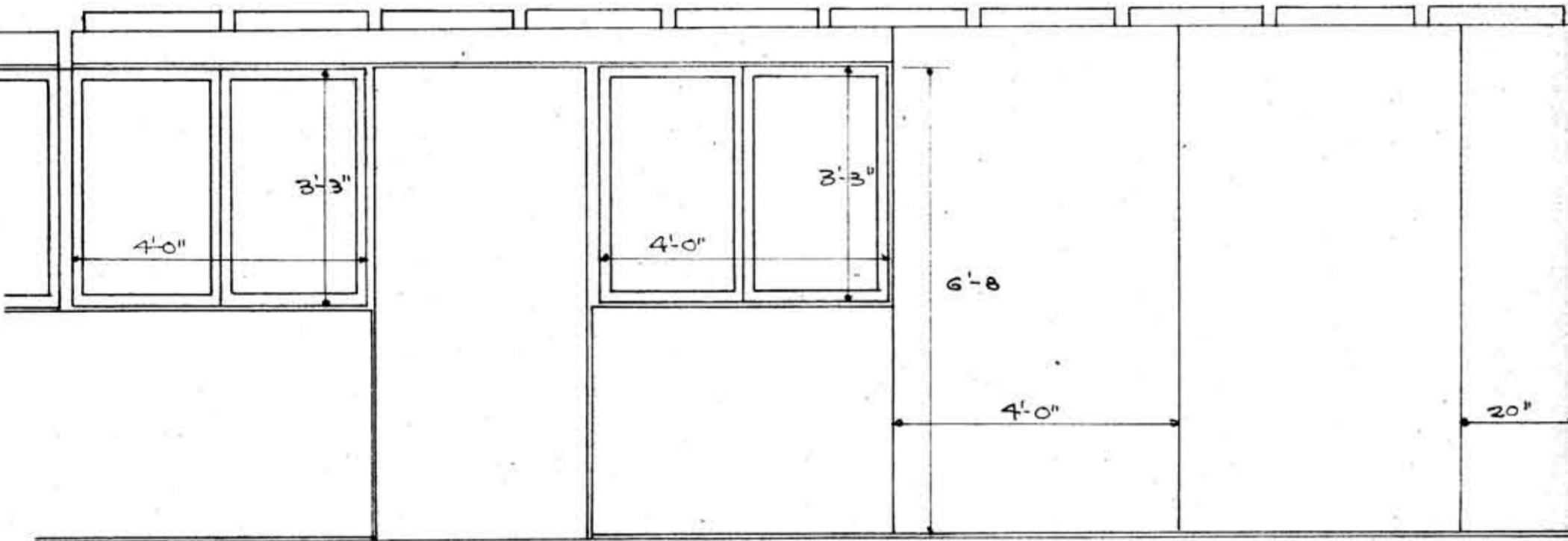

KITCHEN WALLS SCALE 1/2" = 1'-0"

BETTER HOMES & GARDENS  
★★★★ HOME PLAN

NUMBER 1503  
THIS PLAN CONFORMS TO THE STANDARDS OF THE  
FEDERAL HOUSING ADMINISTRATION  
FOR MINOR LOCAL VARIATIONS SEE YOUR  
F.H.A. REGIONAL OFFICE  
SHEET NO 4

DESIGNED BY W. D. RIDDLE A.I.A. CLEVELAND OHIO



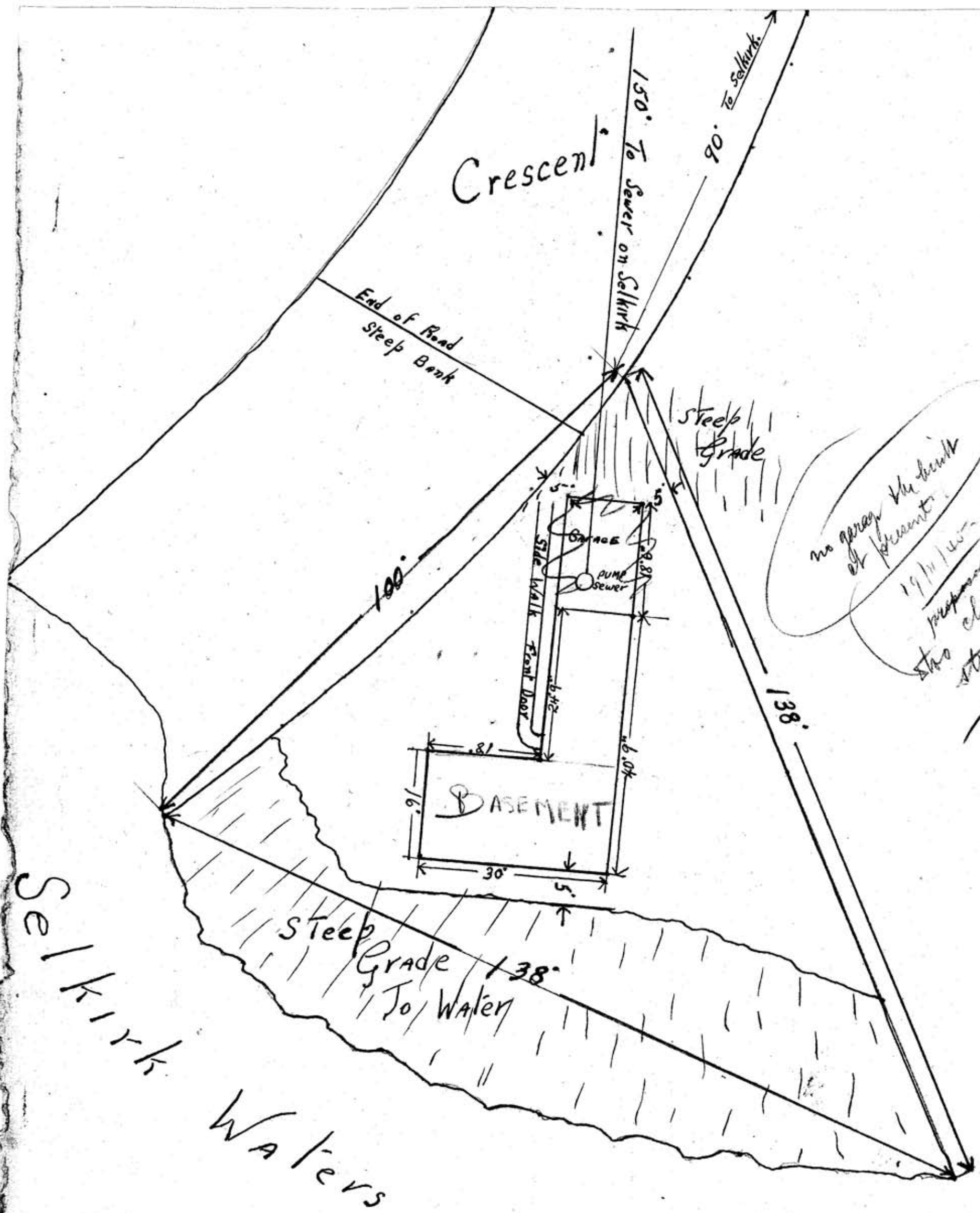

Map # 969

Lot # 15

Scale 1/16" = 1 ft